



EWPC 971

freezer control

WHAT IT IS

The EWPC 971 is a micro-processor based digital controller designed for "electric or hot-gas defrost with temperature termination" applications in the medium or low temperature range.

HOW IT IS MADE

- **Housing:** black ABS plastic, self-extinguishing
- **Dimensions:** front 74x32 mm (2.913x1.260"), depth 67 mm (2.637")
- **Mounting:** flush panel mount with mounting bracket
- **Protection:** the instrument front-panel is waterproof IP65; an optional snap-on cover can be supplied to provide additional protection of the rear terminal block
- **Connections:** screw terminal block (2.5 mm²; one wire each terminal only, in compliance with VDE norms)
- **Display:** 12.5 mm LED (0.50")
- **Push buttons:** located on front panel
- **Outputs:** two (2) relays 8(3)A 250V AC for compressor (SPST) and defrost (SPDT)
- **Inputs:** two (2) PTC probes for temperature and defrost control
- **Resolution:** 1 °C (°F)
- **Accuracy:** better than 0.5% of full scale
- **Power supply:** 12 Vac/dc

GENERAL DESCRIPTION

The EWPC 971 is a micro-processor based digital controller designed for "electric or hot-gas defrost with temperature termination" applications in the medium or low temperature range. It has two output relays for compressor and defrost control, as well as two PTC sensor inputs for room and evaporator temperature.

The EWPC 971 is supplied in the popular "32x74" ELIWELL housing and is manufactured according to VDE and UL norms.

OPERATION

The temperature control is always subject to a positive temperature switching differential (make on rise): the compressor stops when setpoint is reached and starts again upon reaching the setpoint temperature plus the differential (hysteresis).

A choice of two defrost types is available: electric defrost (during which the compressor stops) or hot gas defrost (during which the compressor is running). Other programming options include: defrost frequency time, time count mode, defrost termination temperature, and a defrost safety limit (time-out).

A number of compressor short-cycle protection solutions (i.e., delay on start, delay at switching off, delay between two successive starts) are incorporated in the system. Thanks to a wide selection of other available parameters the controller can be adapted to virtually any application requirement.

FRONT KEYPAD

SET: push and release to display the setpoint for 5 seconds. During this period the "SET" status light is on and the setpoint can be changed with the "UP" or "DOWN" button only. The system will automatically switch to normal display after 5 seconds upon release of buttons and the new value will be memorized.

UP: used to increase the setpoint value, as well as the parameter when in programming. When held down for a few seconds, the change rate accelerates.

DOWN: same functions except to decrease a value.

DEFROST: this momentary push button will start a manual defrost cycle whenever it is activated for at least 5 seconds; not accessible when in setpoint or parameter programming. The programmed interval to the next defrost cycle is automatically reset. The "DEF" goes on when the defrost is initiated, whether the defrost is manual or automatic.

Led "COMP": status light of the internal compressor relay. It is ON when the compressor is ON.

Led "SET": it is on during Setpoint display and programming; it blinks during parameter programming.

Led "DEF": status light of the defrost. It is on during automatic defrost; it blinks during manual defrost.

PARAMETER PROGRAMMING

Programming is easily accessed by holding the "SET" button down for more than 5 seconds; the first parameter is displayed while the status light "SET" remains blinking during the programming period.

Other parameters are accessed with the "UP" and "DOWN" button. With the "SET" button, the actual setting of each parameter is displayed. It can be changed with "UP" and "DOWN".

The system will autom. return to its normal operating mode a few seconds after the programming procedure is completed or interrupted.

DESCRIPTION OF PARAMETERS

diF: differential.

Switching differential (hysteresis); it will always be set with positive value (make on rise).

LSE: Lower SET.



DEFAULT SETTINGS - STANDARD MODELS

Parameter	Description	Range	Default	Unit
diF	diFferential	1...15	2	°C / °F
LSE	Lower SEt	-99...HSE	-55	°C / °F
HSE	Higher SEt	LSE...99	40	°C / °F
dtY	defrost type selection	EL / in	EL	flag
dit	defrost interval time	0...31	6	hours
dct	defrost count type	dF / rt / SC / Fr	dF	flag
doh	defrost offset	0...59	0	minutes
dEt	def. Endurance time-out	1...99	30	minutes
dSt	def. Stop temperature	-70...99	8	°C / °F
dt	drainage time	0...99	0	minutes
dPo	defrost (at) Power on	n / y	n	flag
ddL	defrost display Lock	n / y / Lb	y	flag
cPP	comp. Probe Protection	oF / on	oF	flag
ctP	comp. type Protection	nP / don / doF / dbi	doF	flag
cdP	comp. delay Protection	0...15	0	minutes
odo	output delay (at) on	0...99	0	minutes
EPr	Evap. Probe read-out	/	/	/
CAL	CALibration	-20...20	0	°C / °F
tAb	tAble of parameters	/	/	/

CONNECTIONS

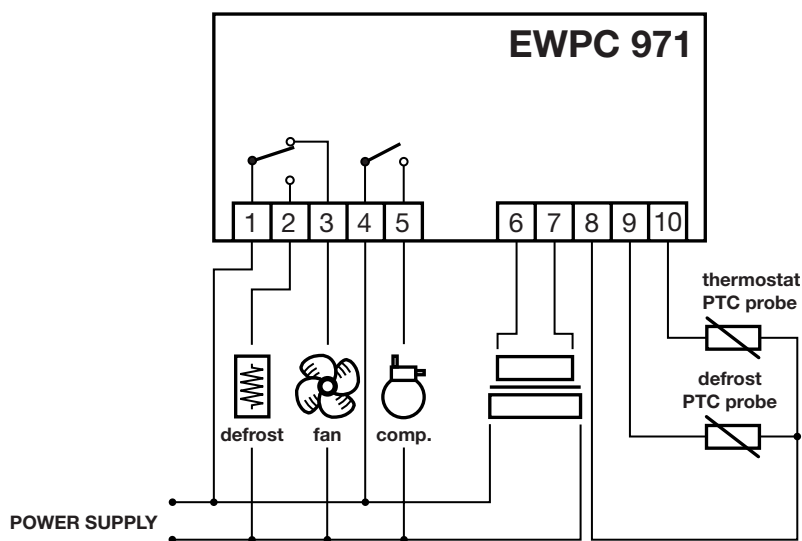

This is the lower limit below which the user cannot change the setpoint.

HSE: Higher SET.

Similar to "LSE", however setting an upper limit for the setpoint.

dtY: defrost type selection.

EL = electric defrost;

in = hot gas (reverse cycle) defrost.

dit: defrost interval time.

Defrost initiation frequency in hours.

dct: defrost count type.

dF = digifrost® Feature; defrost starting time ("dit") is calculated based on accumulative compressor running time.

rt = real time; defrost initiation frequency is based on real time. Time between defrost

starts is always the same.

SC = Stop Compressor; a defrost cycle is activated each time the compressor stops.

Fr = Free (the compressor relay has no relation with the defrost functions and continues to regulate on Setpoint).

doh: defrost offset.

Time delay of defrost start, expressed in min.

dEt: defrost Endurance time-out.

Defrost safety limit, in minutes. Defrost cycle is terminated, regardless whether fully completed.

dSt: defrost Stop temperature.

Adjustable defrost termination temperature.

dt: drainage time.

Upon defrost completion, compressor remains OFF for this amount of time to allow coil drainage; expressed in minutes.

dPo: defrost (at) Power on.

Selects whether the system should go through a defrost cycle at start-up (or after a power failure).

n = no;

y = yes.

ddL: defrost display Lock.

Select whether or not to lock in the actual box temperature display during a defrost.

n = no; during defrost the actual box temperature is displayed.

y = yes; the temperature displayed at the start of a defrost is locked in and does not change during this cycle.

Lb = Label; during the defrost the label "dEF" is displayed to indicate a defrost is in progress.

Note: with the "y" and "Lb" selection, the display remains locked until the box temperature is pulled down again and reaches setpoint.

cPP: compressor Probe Protection.

Select compressor relay status in case of room probe defect.

oF = comp. OFF in case of probe defect;

on = comp. ON in case of probe defect.

ctP: compressor type Protection.

Select the type of (short-cycle) protection best suited for the compressor; the actual delay time is programmed with the next parameter.

nP = no Protection.

don = delay on start; delay applies when relay is energized.

doF = delay at switching oF. Minimum off-cycle time period.

dbi = delay between two successive starts. Limits the number of start-ups per hour.

cdP: compressor delay Protection.

The time delay - in minutes - applicable to the previous parameter "ctP".

odo: output delay (at) on.

Time delay in minutes applied to activation of the relays after start-up.

EPr: Evaporator Probe read-out.

With this parameter the evaporator temperature can be displayed, even during normal operation.

CAL: CALibration.

Temperature read-out offset to allow for a fixed adjustment up or down due to probe location, if desired.

tAb: tAble of parameters.

This shows the configuration of the parameters as set in the factory; can not be modified (for factory identification and diagnostic purposes only).

INSTALLATION

The instrument is designed for flush panel mounting. Insert the unit through a 71x29 mm panel cut-out and affix with the U-bracket supplied.

The ambient temperature around the instrument should be kept between -5 and 65 °C (23...149 °F).

Select a location which will not be subject to high humidity or condensation and allow some ventilation to provide cooling to the instrument.

ELECTRICAL WIRING

The instrument is equipped with an internal screw terminal block suitable for $\leq 2.5 \text{ mm}^2$ wiring (one wire each terminal only, in compliance with VDE norms). Make sure that the power supply corresponds with the rating shown on the instrument, i.e. 12 Vac/dc $\pm 15\%$.

The 2-wire PTC type probe does not require polarity and can easily be extended by using common 2-lead wire. It is strongly recommended to run the probe cable separate from line voltage wiring.

Also, it is good practice to install the tip of the probe in upright position, to avoid moist from entering into the stainless steel sensor housing. The compressor relay contacts are voltage-free and are suitable for in-line switching of compressors up to 0.5 HP at 220 Vac (or 0.25 HP to 110 Vac). For larger loads, an external contactor must be used.

ERROR ANNOUNCEMENT

The instrument causes the display to read "E1" in the event of a problem with the box probe. This could mean: either an open or shorted sensor, sensor not connected, temperature "under range" (below $-55 \text{ }^\circ\text{C}$ or $-67 \text{ }^\circ\text{F}$) or temperature "over range" (over $99 \text{ }^\circ\text{C}$ or $210 \text{ }^\circ\text{F}$).

An error reading "E2" means a problem with the evaporator probe. It is recommended to double-check the sensor wiring before diagnosing a probe as defective.

TECHNICAL DATA

Housing: black ABS plastic, self-extinguishing.

Dimensions: front 74x32 mm (2.913x1.260"), depth 67 mm (2.637").

Mounting: flush panel mount with mounting bracket.

Protection: the instrument frontpanel is waterproof IP65; an optional snap-on cover can be supplied to provide additional protection of the rear terminal block.

Connections: screw terminal block (2.5 mm^2 ; one wire each terminal only, in compliance with VDE norms).

Display: 12.5 mm LED (0.50").

Push buttons: located on front panel.

Data storage: non-volatile EEPROM memory.

Operating temperature: $-5...65 \text{ }^\circ\text{C}$ ($23...149 \text{ }^\circ\text{F}$).

Storage temperature: $-30...75 \text{ }^\circ\text{C}$ ($-22...167 \text{ }^\circ\text{F}$).

Outputs: two (2) relays 8(3)A 250V AC for compressor (SPST) and defrost (SPDT).

Inputs: two (2) PTC probes for temperature and defrost control.

Resolution: $1 \text{ }^\circ\text{C}$ ($^\circ\text{F}$).

Accuracy: better than 0.5% of full scale.

Power supply: 12 Vac/dc $\pm 15\%$.

DISCLAIMER

This manual and its contents remain the sole property of Invensys Climate Controls s.p.a., and shall not be reproduced or distributed without authorization. Although great care has been exercised in the preparation of this document, Invensys Climate Controls s.p.a., its employees or its vendors, cannot accept any liability whatsoever connected with its use. Invensys Climate Controls s.p.a. reserves the right to make any changes or improvements without prior notice.



Invensys Climate Controls s.p.a.

via dell'Industria, 15

Zona Industriale Paludi

32010 Pieve d'Alpago (BL)

ITALY

Telephone +39 0437 986111

Facsimile +39 0437 986066

Email eliwell@invensysclimate.com

Internet <http://www.climate-eu.invensys.com>

7/2000 ing
cod. 9FT40028